



Front-Wheel Drive Hot Rods

2024 Rules & Regulations

CONTENTS

1. DEFINITION	2
2. WHO CAN RACE	2
3. TYPE OF CAR	2
4. BODYWORK / SPACEFRAME	2
5. ENGINE	3
6. GEARBOX & DIFFERENTIALS	3
7. WHEELS / TYRES	3
8. SAFETY EQUIPMENT	4
9. PERSONAL SAFETY	7
10. ROLL CAGES	7
11. COOLING SYSTEM	8
12. WINDSCREEN / GLASS	8
13. STOP LIGHTS	8
14. MIRRORS	8
15. OIL CATCH TANK	8
16. BATTIERS & ELECTRICAL SYSTEM	8
17. FUEL TANK & SYSTEM	8
18. RACE NUMBER & DRIVERS NAME	9
19. ROOF GRADING	9
20. FINAL PREPARATION	9
21. DISCIPLINARY ACTION	9
22. RULE CHANGES	10

1. DEFINITION

Front-Wheel Drive Hot Rods are a non-contact formula using suitably modified small saloon, coupe, hatchback, Steel Body cars or Pick Ups. Racing is in a clockwise direction. The objective is to complete the specified number of laps in the shortest time.



2. WHO CAN RACE

- *All Front-Wheel Drive Hot Rod Drivers must apply for a Front-Wheel Drive Hot Rod licence which costs £50.00 for the year.*
- *Once registered it then entitles you to pick your race number, subject to availability, and you will be issued with a copy of the Front-Wheel Drive Hot Rod Rules & Specifications.*
- *You may only race if you are pre-booked through the Spedeworth Office. This will be on a first come first served basis, so book early. You will be charged £25.00, which is to be paid in advance for each meeting you want to race at.*
- *Please note that **NO** day licences or temporary licences will be issued! (Subject to promoters discretion).*
- *At a meeting all Drivers must book in at the Pit office with their Log Book, where they will be given an entry ticket for themselves and one complimentary ticket.*
- *You cannot register mechanics for this formula.*
- *You must be a minimum age of 17+ years of age to Race a Front-Wheel Drive Hot Rod.*

3. TYPE OF CAR

- Right-hand drive, front wheel drive, steel bodied small saloon, coupe, hatchback.
- Engines must remain in front of the driver, bulk heads can be moved back to accommodate engine, cars and engines may be interchanged.

4. BODYWORK / SPACEFRAME

- Non-spaceframe cars may be modified to accept any suspension configuration.
- Bulkhead may be modified to allow re-positioning of the engine but must be fabricated in steel to re-establish a complete firewall.

- Body panels may be replaced with fibreglass or Kevlar equivalent except the roof which should remain steel.
- Semi-spaceframe vehicles are permitted.
- Trailer mudguards/side skirts are permitted, and wheel arches must cover all the wheels.
- Aero foil spoilers and splitters are free.
- Bodywork must be always kept tidy and of a professional appearance, no sharp or jagged edges.
- Braking system is free but must be effective on all 4 wheels.
- ***If the driver door is replaced with fibreglass there must be a minimum of one layer of Kevlar on the drivers door.***
- ***Roof pillars must remain standard, no lightening or cutting out within the confines of the roll cage hoops.***
- ***The rear of the bonnet to the windscreen and slam panel must be fire walled i.e. no holes or vents.***
- ***The rear of the bonnet must not be raised.***
- ***A single radiator protection bar may be fitted but this must be no more than 3 inches past the inner chassis member.***
- ***The maximum bar diameter allowed is not more than 36mm by 2mm thick.***
- ***All cars must be fitted with a front and rear bumper. No steel front pane i.e. Stock Rod type.***
- ***When steel arches are fitted the only bracing permitted is to the front and rear section of the arches.***
- ***No bracing is permitted to the top part of the arches to the inner wing.***
- ***Front and rear light apertures must be blanked off.***

5. ENGINE

- Engine must be of a minimum 1600cc (exceptions to this are mini and Austin) there is no upper cc limit.
- Turbo or supercharged cars are not permitted, bike engine cars are not permitted.
- Engine Modifications are free, carburettors and fuel injection systems are free.
- All engines must be fitted with an exhaust and silencer, when fitted it must not exceed 96DB when held at 4000 Revs.

6. GEARBOX & DIFFERENTIALS

- Gearboxes and differentials are free.

7. WHEELS / TYRES

- ~~Maximum of 8 inch wide rim,~~ ***The only rims permitted are 7 or 8 inch wide*** steel or alloy. ***Any rim diameter can be used.***
- ***Maximum tyre width is 205.***
- The only tyre permitted is YOKOHAMA 048R, TOYO R888 / NANKANG AR-1 medium compound with a maximum width of 8 inches.
- Tyre cutting is not permitted and may result in a penalty.

8. SAFETY EQUIPMENT

- CRASH HELMET

Please visit the ORCi website www.orci.co.uk for current safety equipment regulations.

- RACING OVERALLS

Please visit the ORCi website www.orci.co.uk for current safety equipment regulations.

- GLOVES

Please visit the ORCi website www.orci.co.uk for current safety equipment regulations.

- BALACLAVAS

Please visit the ORCi website www.orci.co.uk for current safety equipment regulations.

- NECK BRACE

Please visit the ORCi website www.orci.co.uk for current safety equipment regulations.

- WET WEATHER CLOTHING

Please visit the ORCi website www.orci.co.uk for current safety equipment regulations.

- HEAD RESTRAINT NET/WINDOW NETS

Please visit the ORCi website www.orci.co.uk for current safety equipment regulations.

- 1kg FIRE EXTINGUISHER

Please visit the ORCi website www.orci.co.uk for current safety equipment regulations.

- COMPETITION STYLE DRIVERS SEAT WITH HEAD RESTRAINT

You must have a Competition type Driving Seat with a head restraint. The seat should occupy its original position where possible and be suitably supported at shoulder height and on both of the sides and back, with a suitable framework or seat stiffener's.

If the seat sits behind the cage must be add diagrams within this section of the document. If the modification goes to the floor it must be sat on 23cm square plate 3mm (min.) thick.

Additional wrap around seat support at shoulder height.

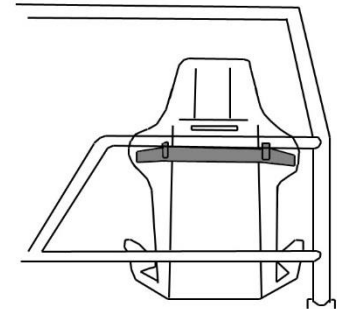

This new section must not be constructed in a way that a drivers helmet can make contact with it. Material od and thickness as rest of roll cage.

FRONT VIEW

SECONDARY SEAT SUPPORT BARS



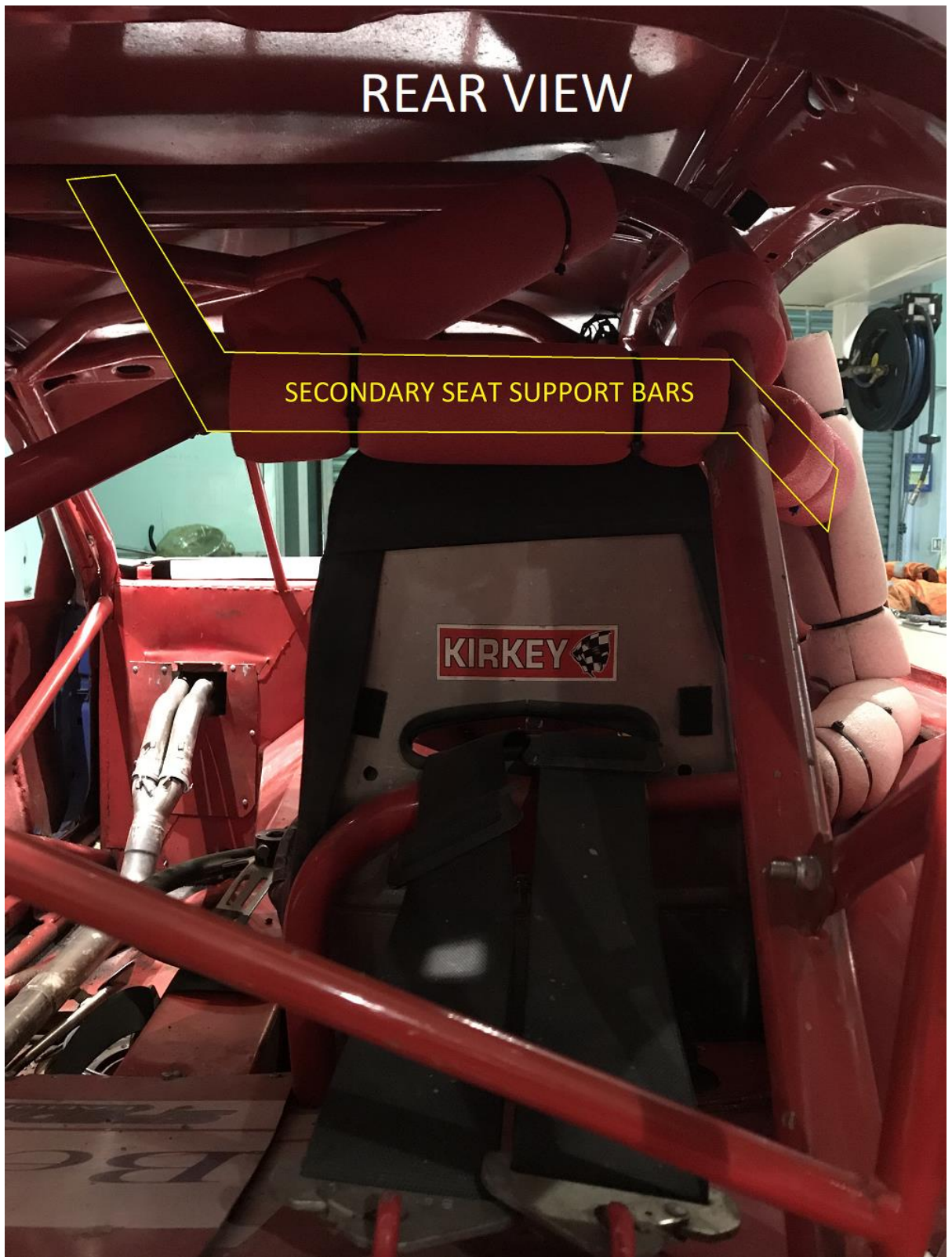

- **SAFETY HARNESS**
Please visit the ORCi website www.orci.co.uk for current safety equipment regulations.

9. PERSONAL SAFETY

Drivers are advised that under Health & Safety, they are responsible for their own and their Mechanic's actions. Promoters have had complaints made about Registered Drivers & Mechanics consuming large amounts of alcohol at meetings, which could effect their judgement or be detrimental to their health, when medical attention has to be administered by Paramedics, St Johns or Hospital Staff.

Should an incident occur that proves fatal on the raceway and you are involved, it is likely that the Police will want interview you. **If you drive, don't drink!** Scrutineers and Officials will report to the Steward, anybody they believe is under the influence of Drink or Drugs. Drivers whom it is thought are under the influence may be breathalysed.

Drivers should line up on the grid with their engines switched off in the correct points order, unless told otherwise.

The Flags

This is to remind drivers of the flag signals as used by the Starting Marshall and Safety Marshalls on track.

- Waved Green Flag – Go, the race has started.
- Waved Red Flag – Stop racing slow down & stop.
- Chequered Flag – Race winner has crossed the line, continue to race until the Red Flag is shown.
- Held Yellow Flag – Beware, you are approaching a hazard on the track, continue to race.
- Waved Yellow – Slow down rolling lap speed, hold your position, and do not overtake any other cars.
- Waved Blue Flag – Shown to a driver who must hold his racing line. Driver must either hold a line on the inner part of the track or the outer part of the track, not weave between both.
- Blue & White Flag – Give up your track position, you have not taken notice of the Blue flags.
- White Flag with a Blue spot – Oil / debris on the track.
- Waved Black Flag - You are disqualified, pull off the track immediately.
- Black cross on a White board – You may have committed an infringement and may be penalised in the results.
- White Flag with a Red Cross – Technical Disqualification, leave the track immediately.

10. ROLL CAGE

- Alloy roll cages are not permitted.
- A full 6-point roll cage; minimum material size and gauge of all tube as listed below is 32mm (3mm) or 38mm (2.5mm) OD; (which must support both A & B pillars) consisting of a minimum of:
 - Two hoops, either running front-to-rear or side-to-side.
 - Two top hoop connecting bars.
 - One rear hoop cross bar at shoulder height to mount seat support, or a seat brace hoop to mount seat support.
 - One lower bar. - One dash cross bar.
 - Two drivers side chicken bars.
 - 3 roof connecting bars to front hoop.
- Drivers' door bars must be two continuous bars constructed of cage material. Passenger side must have a minimum of 1 bar.
- All structural bars connecting to the cage inside the car must be steel and terminate a minimum of 100mm from the front and rear panel.
- Any part of the cage that may come into direct contact with the driver's body must be suitably padded.
- All joints must be welded over a minimum of 90% of the surface area of the joint. RAC approved cages are permitted with a minimum thickness of 2.5mm.
- It is important there are no large gaps between any part of the cage and the body shell.

11. COOLING SYSTEMS

- Radiators are free and must be forward of the engine in the engine compartment.

12. WINDSCREEN / GLASS

- All glass must be removed.
- A front Perspex or laminated screen may be fitted, but not recommended.
- Rear quarters may be fitted with Perspex.

13. STOP LIGHTS

- Either two stop lights, or a centrally fitted single stop light must be fitted into the parcel shelf or hung from the roof in the case of hatchbacks. They must be a minimum of 76mm and a maximum of 127mm and must be red in colour.

14. MIRRORS

- Drivers side external door mirror must be fitted.
- A rear-view mirror must be fitted.

15. OIL CATCH TANK

- An oil catch tank, with a minimum capacity of 0.5 litres must be fitted in the engine bay and must have a minimum of two breather pipes connecting to it, one from the rocker box and one from the crank case. If the catch tank becomes ineffective during practice or racing, the car will be withdrawn from the event. ***An adequate catch tank must be fitted to the radiator or header tank.***

16. BATTERIES & ELECTRICAL SYSTEMS

- Batteries must be securely fixed securely and covered with a rot proof material.
- Contact between battery and safety harness must not be possible.
- Battery must be a minimum of 152mm from fuel tank.
- A battery master switch must also be fitted to the passenger side rear window aperture and must be also marked clearly ON/OFF.
- If an electric fuel pump is fitted, a switch must be within easy reach of the driver.
- All cars must be fitted with a red ignition light which must remain on when electrical system is active.

17. FUEL TANK & SYSTEM

- All fuel tanks must have a positive means of fixing (metal straps or bolts).
- Filler caps must not be prone to spillage – no push on caps. Caps must be metal and secure, or screw on type.
- Fuel tanks and fuel pumps must be covered by a metal firewall.
- Fuel outlet must be from the top of the tank.
- A breather pipe, which must incorporate a one-way valve, must be fitted.

- All fuel lines must be inside of the vehicle *and fitted by means of a 'P' clip only with adequate spacing.*
- Only roadside fuel can be used (BP ultimate, Shell V-Power or ESSO supreme) No additives are permitted.
- A fuel shut off tap must be fitted within easy reach of the driver.
- All fuel lines must be metal, or metal covered, rubber is not permitted.
- Fuel tanks must be metal and a maximum of 2.5 gallons.

18. RACE NUMBER & DRIVERS NAME

- Side of car – The driver's number must appear on both sides of the car; these should be large and in contrasting colours to paintwork and must be a minimum of 12 inches high.
- Fin plates/Aero foil – Numbers should be a minimum of 229mm high and be contrasting to the background. They should be on each side of the car.
- Race numbers must also be fitted in the centre of the roof.
- Driver's name – A sun visor to an approximate depth of 152mm with your name or nickname clearly sign written must be fitted.

19. ROOF GRADING

- You must start in the correct roof grade, you may be penalised if not, your roof grade colour must also be clearly painted on your car.
 - White
 - Yellow
 - Blue
 - Red
 - Superstar
 - Points Champions, Track champions start at the back of the grid behind all the other cars.
- Roof Grading will be looked at monthly by officials and released to allow adequate time to ensure you have the correct colour painted.

20. FINAL PREPARATION & COLOURS

- All cars must maintain a tidy and professional appearance and all race damage must be repaired after each meeting.
- No childish drawings or offensive slogans are permitted.
- Scrutineers are instructed to refuse any car which they would consider unsafe, unsightly, or in any way offensive.
- All previous race meetings damage must be repaired between race meetings failing to this will result to failure when scrutineering.

21. DISCIPLINARY ACTION

- Black cross will result in a minimum of being docked two places.
- Black flag will result into a minimum of a two-race ban.
- All drivers must act in professional manner this includes their race team and supporters any abusive language or behaviour to any race official or any other driver will result in an immediate ban.
- Please remember you are on show to spectators and the public eye.

22. RULE CHANGES

- The officials may at any time may make amendments or changes to rules, in the interest of health and safety.

**REVISED RULES FOR 2024 HIGHLIGHTED IN BOLD/ITALIC RED PRINT
ITEMS MARKED ~~STRIKETHROUGH~~ ARE NO LONGER ALLOWED
2024 Front-Wheel Drive Hot Rods Technical Specifications, Issue 1, Dated 13th
February 2024.**